

2" Deep Bolted Stringer Understructure for ConCore® 3000 Floor Panels-24". Type 2CF Pedestal Crimped for 3/4" stud.

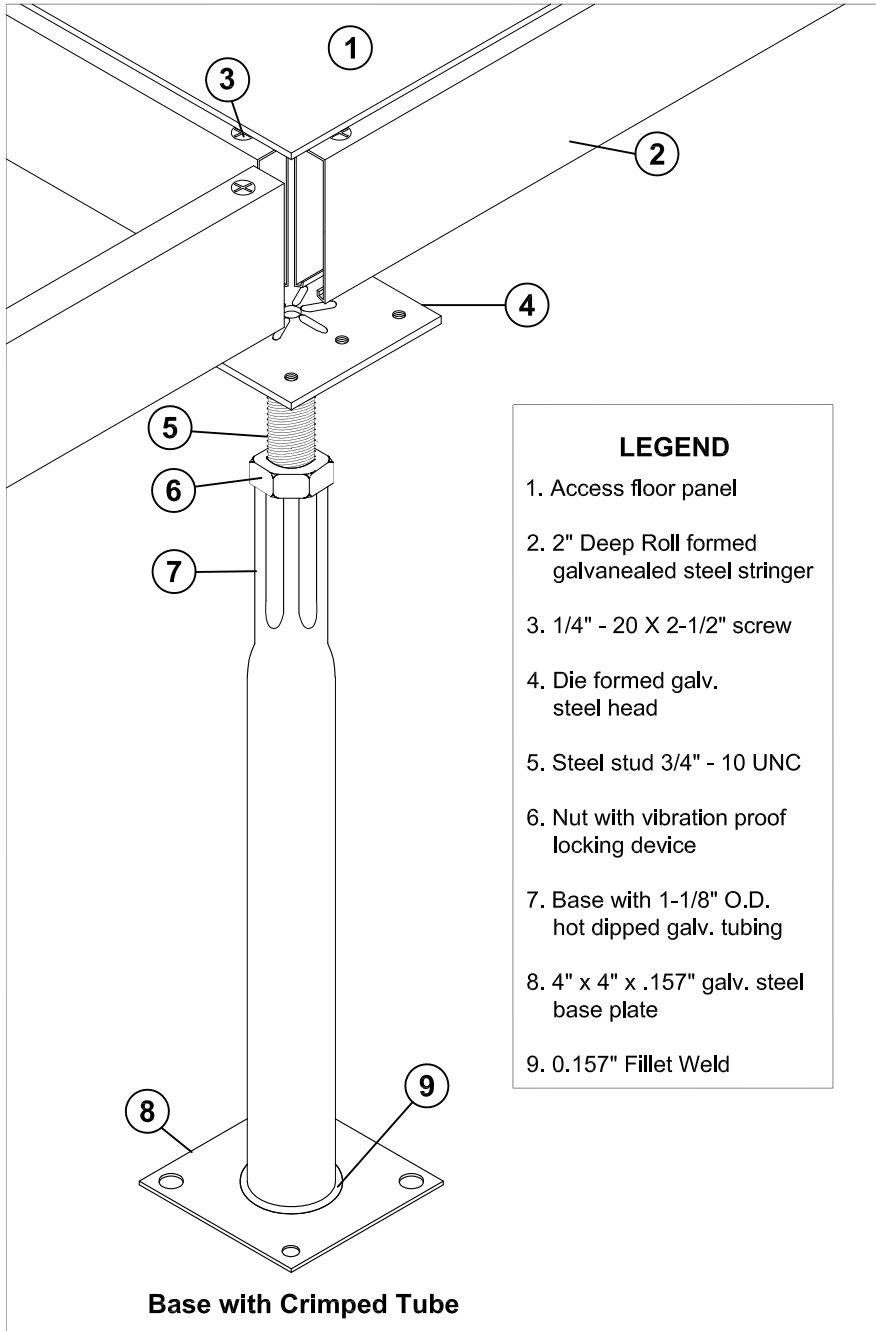

PEDESTAL SPECIFICATIONS

Pedestal Assembly

- Assembly up to 36" FFH shall provide an 8,000 lb. axial load without permanent deformation.
- Assembly shall provide a 2" total adjustment.
- All pedestal components and fasteners are completely electro-zinc free.

Pedestal Head

- 8 ga. die formed galvanized steel pedestal head with fillet welded stud with adjustment nut. Head and installed stringers shall provide full perimeter edge support for panel.
- Stringers shall be attached with 1/4" - 20 flat-head screws.
- Pedestal head shall be tapped for engagement of stringer screws.
- Steel stud shall be 3/4" - 10 UNC.
- 3/4" - 10 UNC adjustable nut with corrosion resistant coating

Pedestal Base

- Base to be at least 16" square and galvanized steel and shall have (2) 7/16" diameter holes and (2) 3/16" diameter holes for mechanical fastening applications.
- Pedestal tube to be 1-1/8" diameter hot dipped galvanized tubing and shall be reduced to 3/4" inner diameter by crimping.

Stringers

- Heavy duty roll formed steel stringer shall be 2" deep X 3/4" wide and shall withstand 1250 lb. mid-span load.
- Galvannealed stringer construction to prevent corrosion. Zinc electroplating is prohibited.
- Stringer grid pattern shall be 4/4' basketweave.

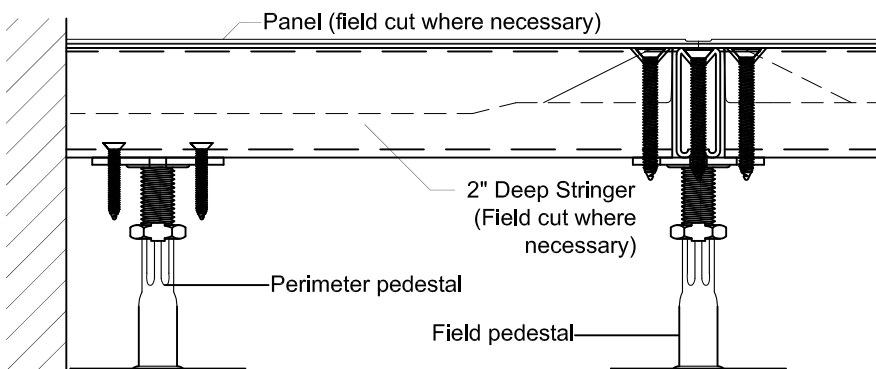
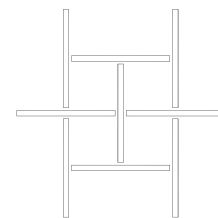

Perimeter

- Perimeter pedestal shall provide support for panels around columns, at walls, curbs and fascia.