

SPECIFICATIONS

General information

- Panel weight : 10.25 lbs./ft² bare.
- All steel welded construction filled internally with a cementitious core material.
- Protected from corrosion by an epoxy paint finish.
- Class A flame spread rating.
- Non-combustible material.

UNDERSTRUCTURE OPTIONS

- 4' Heavy Duty Bolted Stringer w/ 8 ga. fillet welded heads

COVERING OPTIONS

Tile factory laminated with integral trim edge

- 1/8" HPL _____ (Color) _____
- 1/16" HPL _____ (Color) _____
- 1/8" Conductive HPL _____ (Color) _____
- 1/16" Conductive HPL _____ (Color) _____

For additional laminate options contact Inside Sales

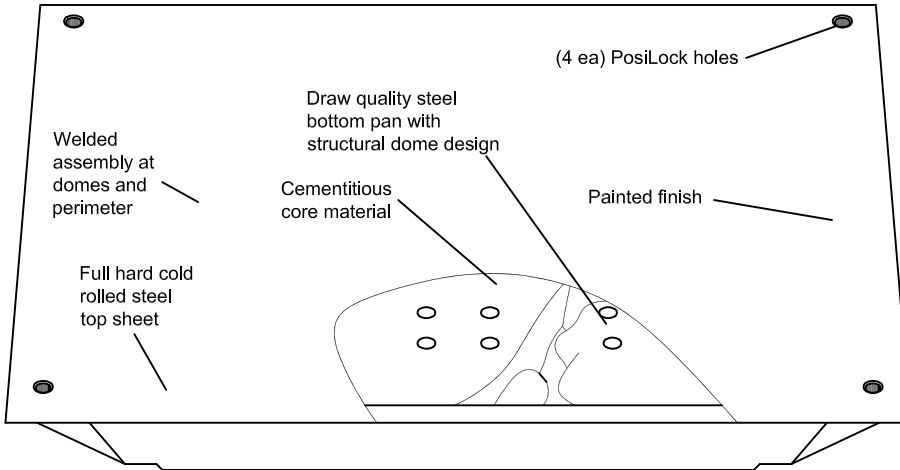

TOP VIEW

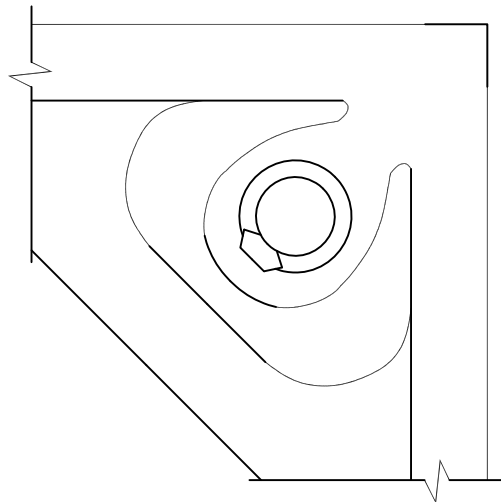

CORNER DETAIL

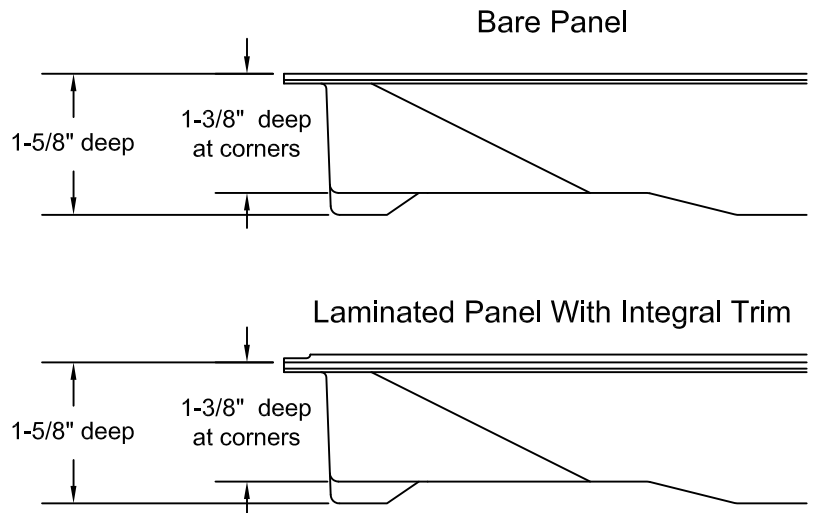

System Performance Criteria

System performance criteria are the most important to consider because they represent the performance in a typical installation. Panel only criteria such as concentrated load is often used to specify floor systems however, the test is not representative of an actual installation because it is performed with the panel resting on blocks, not actual understructure.

System Performance Criteria (Tested on Actual Understructure)*								
System Type	Understructure	SYSTEM WEIGHT	STATIC LOADS			ROLLING LOADS		IMPACT LOADS
			Design Loads	Ultimate Loads	Safety Factor	10 Passes	10,000 Passes	
ConCore CC2000-24"	Bolted Stringer	11.5 lbs / ft² 56 kg / m²	2000 lbs 907 kg	Min. 4000lbs Min. 1814kg	Min. 2	1500 lbs 680 kg	1250 lbs 567 kg	200 lbs 91 kg

1. All load tests are performed using the CISCRA Recommended Test Procedures for Access Floors with the exception of Design Load. Design Load capacities are verified using the CISCRA Concentrated Load procedure (with loads applied through a 1" dia. indenter at the weakest point) but with the panels supported by actual understructure rather than steel blocks. (Tests on panels supported by blocks are not representative of panel or system performance in actual installations.)

2. Safety factor is Ultimate load divided by Design load.